

### SPECIFICATIONS

Design	1586	Lit./min(50Hz)
Displacement	1983	Lit./min(60Hz)
Speed	1400	r.p.m. (50Hz)
	1750	r.p.m. (60Hz)
Normal usage	Under	Torr
Attainable vacuum pressure	Max 17torr	
Suction port diameter	JIS 40A (2) (Option: B.S.P.T)	
Motor	Horizontal Motor Standard	
	3-Phase 220/380V 60Hz 3.7kW 4P	
Water Capacity	15 C 기준	12L/MIN
Weight	140	Kg
Painting	Color- VL951	
	(Company's standard)	
Allowable ambient temp.	-10 - 40C	

-1 Excluding motor and some other parts.

Curve referred to dry air at 20°C (68°F) 배기량 SUCTION CAPACITY

배기수 온도 15 C 기준

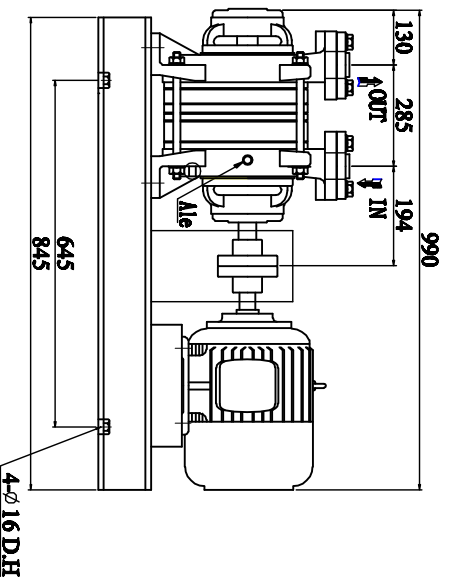
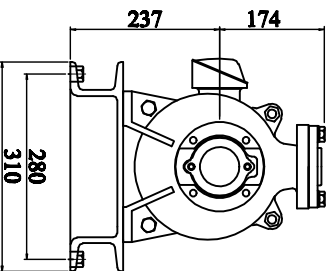
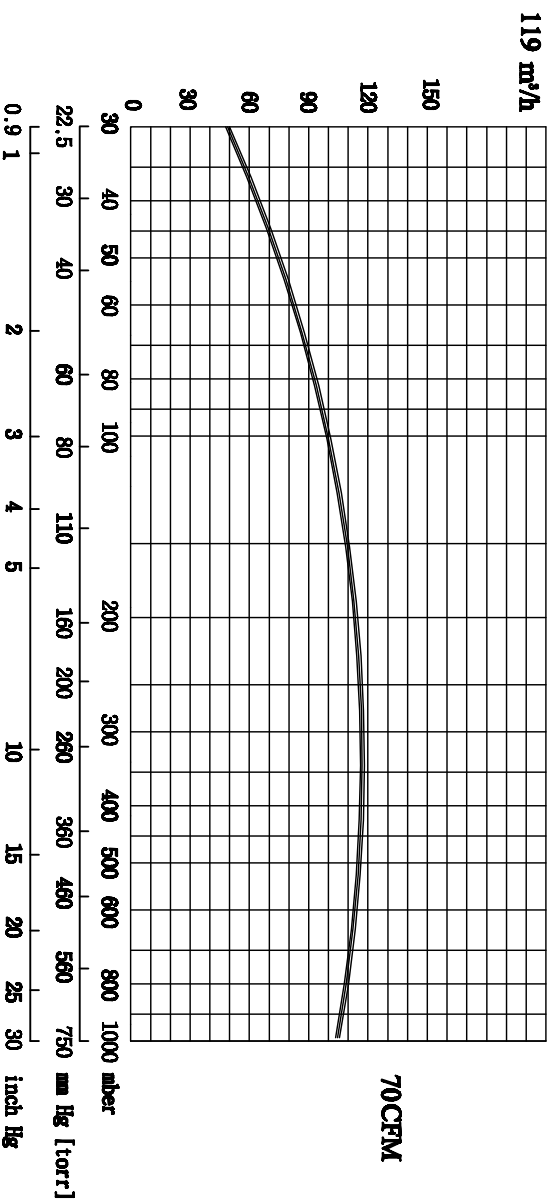

### ACCESSORIES(OPTION)

- Vacuum Manual Valve
- Vacuum gauge
- Vacuum Check Valve
- Separator Tank

### CONSUMABLE LIST

(VACUUM RING GENUINE PARTS)

Designation	Specification	Quantity/set
M/C Seal	φ 32	2
Bearing	6206 ZZ (Special Heat - resisting grease)	2
Half Coupling	φ 85	1
Shaft key	φ 28 8x4	1

DWG DATE	SCALE	N/S	TITLE
2000.00.00			WATER RING V/P
DWG BY	DESIGN BY	CHD BY	APPROVE
			CLIENT
			LOCATION

- 품질 개선을 위해서 예고없이 변경 될수 있음.
- Not binding dimension that can change according to motor make

 진공엔지니어링

DWG NO JHRP2-6