

SPECIFICATIONS

Design	11872 Lit./min(50Hz)
Displacement	14840 Lit./min(60Hz)
Speed	1400 r.p.m. (50Hz) 1750 r.p.m. (60Hz)
Normal usage	Under Torr
vacuum pressure	
Attainable vacuum pressure	Max 17torr
Suction port diameter	JIS 80A (2) (Option:B.S.P.T)
Motor	Horizontal Motor Standard 3-Phase 220/380V 60Hz 30kW 4P
Water Capacity	15°C 기준 54L/MIN
Weight	Kg
Painting	Color- VL951 (Company's standard)
Allowable ambient temp.	-10 - 40C

-1 Excluding motor and some other parts.

Curve referred to dry air at 20°C (68°F) 배기량 SUCTION CAPACITY
 배기수 온도 15°C 기준

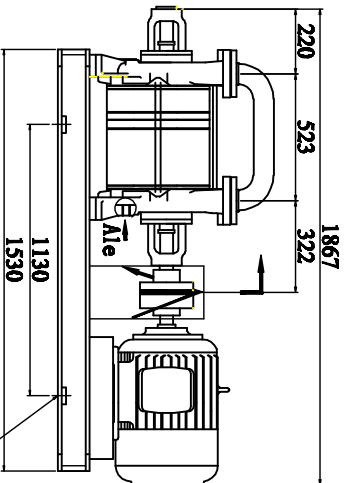
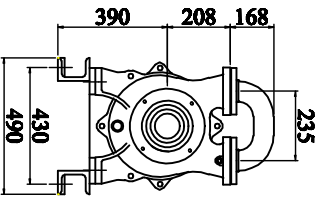
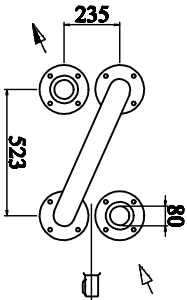
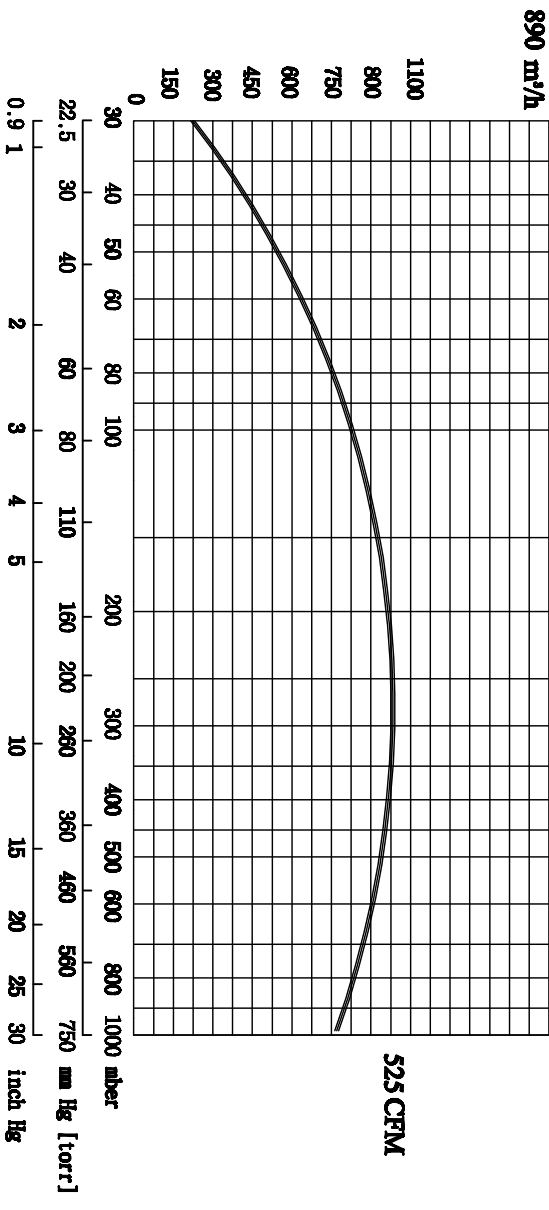

- ACCESSORIES(OPTION)**
- Vacuum Manual Valve
 - Vacuum gauge
 - Vacuum Check Valve
 - Separator Tank

CONSUMABLE LIST
(Vacuum ENG GENUINE PARTS)

Designation	Specification	Quantity/set
M/C Seal	φ 60	2
Bearing	6310 ZZ (Special Heat - resisting grease)	2
Half Coupling	φ150	1
Shaft Key	φ 42 12X8	1

DWG DATE	SCALE	N/S	TITLE
2000.00.00			WATER RING V/P
DWG BY	DESIGN BY	CHD BY / APPROVE	CLIENT
			LOCATION

— 품질 개선을 위해서 예고없이 변경 될수 있음.
 — Not binding dimension that can be changing to motor maker



DWG NO JHRP2-20B